

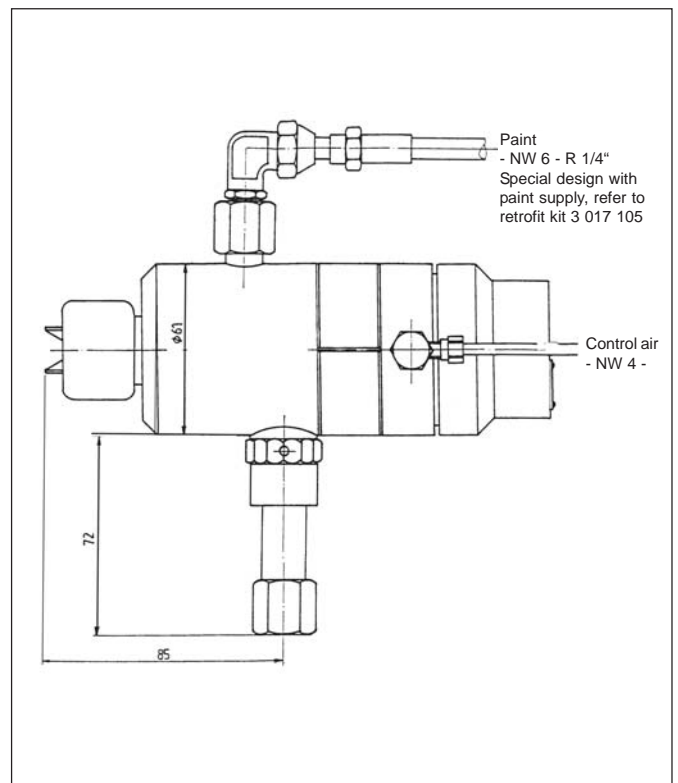

PERFECT FINISH – PAINTED BY THE SPECIALIST.

Airless Gun MAE 7-059-Ex

ATEX tested spraying system for zone 2



With this spraying system the high pressured painting material is atomized when leaving the nozzle.

The required quantity and quality of paint determine the used nozzle size; flat and round nozzles adapt to the different painting requirements.

The pneumatic activated valve allows very short switching intervals, as needed when working with automatic controls, where paint is switched off at the edge of work pieces.

Features

- Paint valve activated by pneumatic control piston
- Paint valve close to nozzles
- Shortest gun trigger times for automatic control
- Optional paint circulating
- Permitted in explosion hazardous area of zone 2



PERFECT FINISH – PAINTED BY THE SPECIALIST.

Technical Data

Airless Spraying System MAE 7-059-Ex – Atex tested for zone 2

Weight without supply lines:	1,0 kg
Weight with supply lines:	1,2 kg
Weight support:	1,8 kg
Total weight:	3,0 kg
Paint operating pressure:	max. 160 bar
Paint throughput:	according to the used paint nozzles
Control air pressure:	max. 8 bar min. 5 bar