



PERFECT FINISH – PAINTED BY THE SPECIALIST.

# Fanuc Robot P-50iA



The FANUC robot P-50iA is a compact robot. Its small size is ideal for companies with floor space constraints. The P-50iA offers easy setup and maintenance, a large work envelope, and fast acceleration, resulting in minimized cycle times and lower production costs.

The six-axis P-50iA has a modular construction, is electric servo-driven, able to operate in hazardous environments, and is supported by our extensive service and parts network.

## **P-50, the solution for:**

- Painting, coating and dispensing
- Space limitations

## **Features and benefits**

- Floor, invert, and wall mounting permits versatility when unusual work piece access is required
- Patented, production proven, hollow wrist and through arm hose routing provide a clean application environment

- Grease fittings on all lubrication points allow for quick and easy maintenance
- Absolute serial encoders eliminate the need for calibration at power-up
- Patented purge system for operation in hazardous environments
- FM and CE Hazardous approval for Class I and II, Div. 1, Groups C, D, E, F, G environments
- Flexible field hose allows fast installation
- Lifting fixture for easy installation of wall or ceiling mount (option)
- Large envelope capable of working on both sides of the robot
- Narrow base minimizes booth space and impact to air-flow
- Handles a variety of applicators including conventional and electrostatic air spray guns and rotary atomizers

## **Process advantages**

- User-friendly Accuflow™ closed-loop fluid delivery system automatically maintains programmed flow rates, providing consistent material delivery and high finish quality (option)
- Collision Guard™ monitors for unexpected interference to reduce machine and applicator damage and maximize uptime (option)
- Integrated micro valve colour changer for short colour change times and waste reduction (option)
- Able to use manifold-mount robot spray guns and rotary atomizers
- Extremely fast acceleration and deceleration motion results in faster cycle times

## **Reliability and maintenance benefits**

- Standard RV drives
- Fully sealed drives
- Long lube cycle

PERFECT FINISH – PAINTED BY THE SPECIALIST.

## Dimensions – Fanuc Robot P-50iA

Isometric

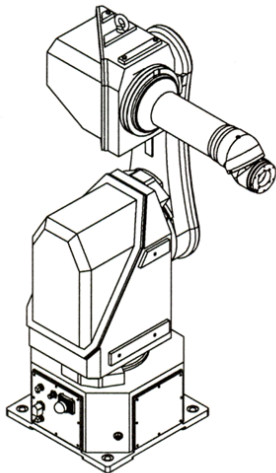

Footprint

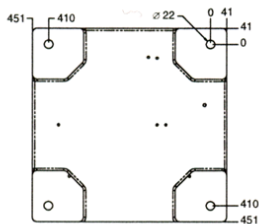

Top

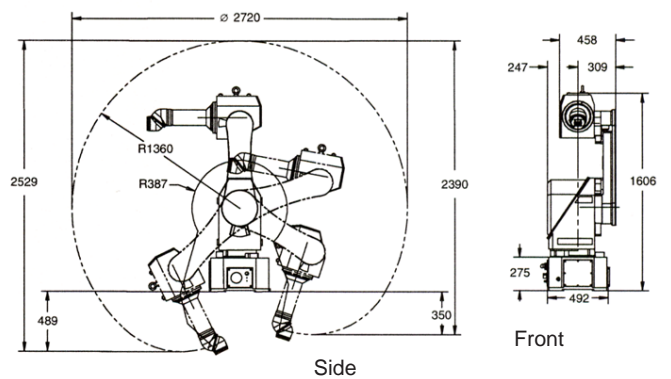
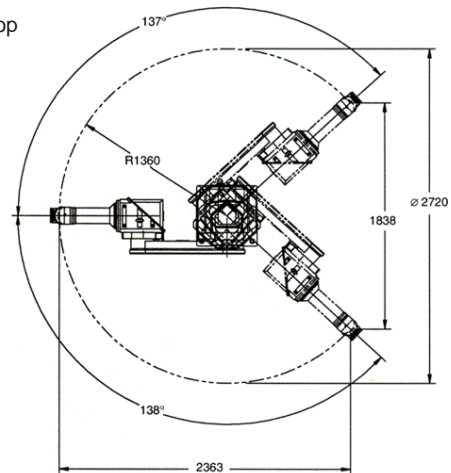

Side

Front

Wrist

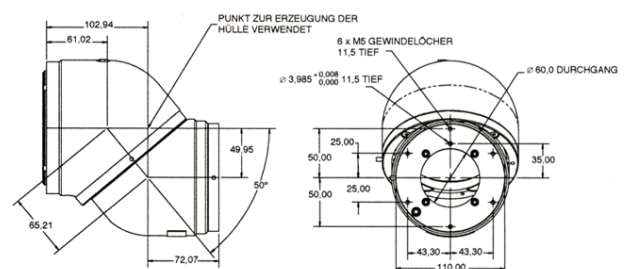

### Specifications

Items	Motion range	Motion speed
J1	± 137,5°	160°/s
J2	± 136°	160°/s
J3	± 147°	160°/s
J4	± 540°	460°/s
J5	± 540°	480°/s
J6	± 540°	600°/s

Configuration	6-axis vertically articulated
Axes	6
Payload wrist	up to 7,5 kg
Outer arm payload <sup>(A)</sup>	up to 5 kg
Max. reach	1360 mm
Repeatability	± 1
Coating speed	up to 1500 mm/sek
Mechanical brakes	Axes 2, 3 (optional 1,4,5,6)
Mechanical weight	254 kg
Mounting method	Floor, wall <sup>(B)</sup> , invert
Certification	FM Class I, II, III/Div. I, Group A, B, C, D, E, F, G

<sup>(A)</sup> Mounted on top of elbow

<sup>(B)</sup> Wall mount requires brakes on axis 1